

ITEM NO.	PARTNUMBER	QTY.	Description	LENGTH	ITEM NO.	PARTNUMBER	QTY.	Description	LENGTH
11	011	1	Tube 1.000 x 0.065	12	51	051	1	Tube 1.000 x 0.049	20.312
12	012	1	Tube 1.000 x 0.065	15	52	052	1	Tube 1.000 x 0.049	20.312
13	013	1	Tube 1.000 x 0.065	14.08	53	053	1	Tube 1.000 x 0.049	20.024
14	014	1	Tube 1.000 x 0.065	14.08	54	054	1	Tube 1.000 x 0.049	20.024
15	015	1	Tube 1.000 x 0.095	54.597	55	055	1	Tube 1.000 x 0.049	19.069
16	016	1	Tube 1.000 x 0.095	14	56	056	1	Tube 1.000 x 0.049	19.069
17	017	1	Tube 1.000 x 0.095	100.814	57	057	1	Tube 1.000 x 0.049	21.341
18	018	1	Tube 1.000 x 0.095	20	58	058	1	Tube 1.000 x 0.049	21.341
19	019	1	Tube 1.000 x 0.049	14.883	59	059	1	Tube 1.000 x 0.049	9.047
20	020	1	Tube 1.000 x 0.049	17.383	60	060	1	Tube 1.000 x 0.049	9.047
21	021	1	Tube 1.000 x 0.049	10.078	61	061	1	Tube 1.000 x 0.049	18.456
22	022	1	Tube 1.000 x 0.049	10.078	62	062	1	Tube 1.000 x 0.049	18.456
23	023	1	Tube 1.000 x 0.065	28.018	63	063	1	Tube 1.000 x 0.049	15.548
24	024	1	Tube 1.000 x 0.065	28.018	64	064	1	Tube 1.000 x 0.049	15.548
25	025	1	Tube 1.000 x 0.049	28.638	65	065	1	Tube 1.000 x 0.049	17.427
26	026	1	Tube 1.000 x 0.049	28.638	66	066	1	Tube 1.000 x 0.049	17.427
27	027	1	Tube 1.000 x 0.065	32.213	67	067	1	Tube 1.000 x 0.049	36.978
28	028	1	Tube 1.000 x 0.065	32.213	68	068	1	Tube 1.000 x 0.049	36.978
29	029	1	Tube 1.000 x 0.065	34.665	69	069	1	Tube 0.875 x 0.049	30.195
30	030	1	Tube 1.000 x 0.065	34.665	70	070	1	Tube 0.875 x 0.049	19.285
31	031	1	Tube 1.000 x 0.065	30.599	71	071	1	Tube 0.875 x 0.049	10.909
32	032	1	Tube 1.000 x 0.065	30.599	72	072	1	Tube 0.875 x 0.049	34.971
33	033	1	Tube 1.000 x 0.049	3	73	073	1	Tube 0.875 x 0.049	20.8
34	034	1	Tube 1.000 x 0.049	3	74	074	1	Tube 0.875 x 0.049	14.171
35	035	1	Tube 1.000 x 0.049	12.885					
36	036	1	Tube 1.000 x 0.049	12.885					
37	037	1	Tube 1.000 x 0.049	15.187					
38	038	1	Tube 1.000 x 0.049	15.187					
39	039	1	Tube 1.000 x 0.049	34.382					
40	040	1	Tube 1.000 x 0.049	34.382					
41	041	1	Tube 1.000 x 0.049	11.75					
42	042	1	Tube 1.000 x 0.049	19.898					
43	043	1	Tube 1.000 x 0.049	10.301					
44	044	1	Tube 1.000 x 0.049	10.301					
45	045	1	Tube 1.000 x 0.049	14					
46	046	1	Tube 1.000 x 0.049	14					
47	047	1	Tube 1.000 x 0.049	14.242					
48	048	1	Tube 1.000 x 0.049	14.242					
49	049	1	Tube 1.000 x 0.049	16.923					
50	050	1	Tube 1.000 x 0.049	16.923					

DISCLAIMER: MODEL AND DRAWING ARE FOR DISCUSSION/ TEACHING PURPOSES ONLY. THE MODEL DOES NOT COMPLY WITH SAE RULES & REGULATIONS. IT HAS BEEN MADE AVAILABLE STRICTLY AS A TEACHING TOOL.

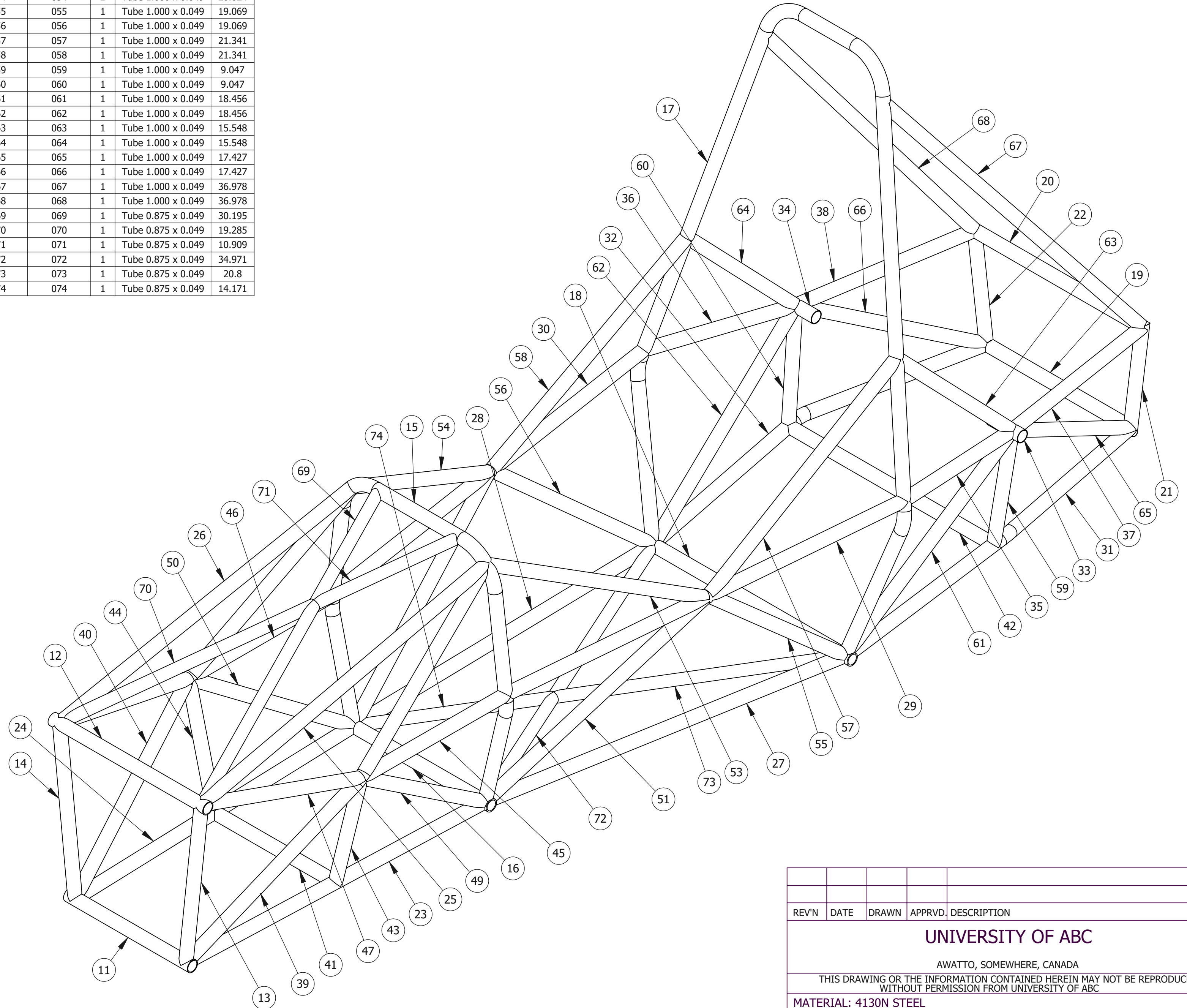

REV'N	DATE	DRAWN	APPRVD	DESCRIPTION
UNIVERSITY OF ABC				
AWATTO, SOMEWHERE, CANADA				
THIS DRAWING OR THE INFORMATION CONTAINED HEREIN MAY NOT BE REPRODUCED WITHOUT PERMISSION FROM UNIVERSITY OF ABC				
MATERIAL: 4130N STEEL				
LINE2				
LINE3				
DRAWN: P.R.C.	DATE: OCT 22/80	PROJECT NO.	DRAWING NO.	REV NO.
'C' SCALE: 1:5		FSAE '81	10-001-201	0

DISCLAIMER: MODEL AND DRAWING ARE FOR DISCUSSION/ TEACHING PURPOSES ONLY. THE MODEL DOES NOT COMPLY WITH SAE RULES & REGULATIONS. IT HAS BEEN MADE AVAILABLE STRICTLY AS A TEACHING TOOL.

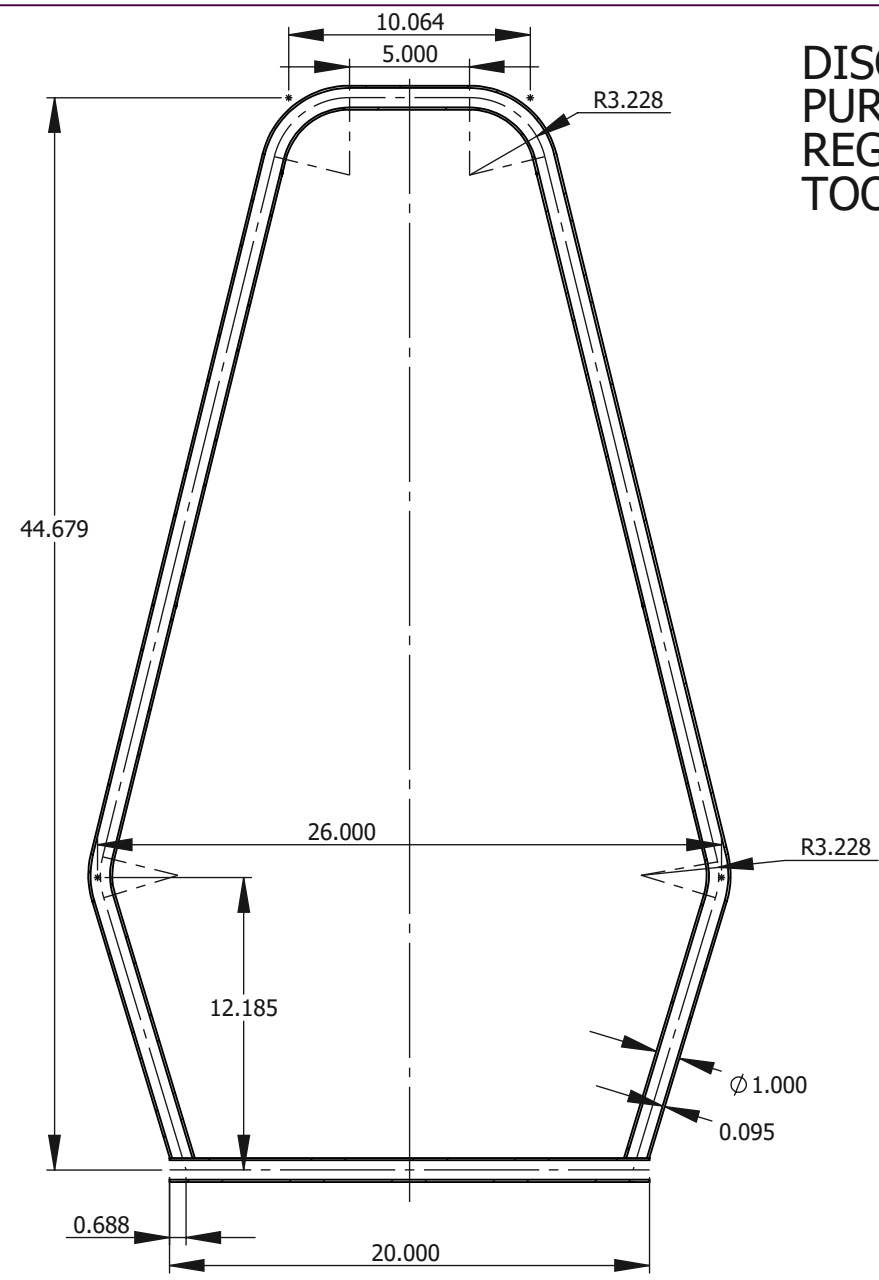

SECTION D-D

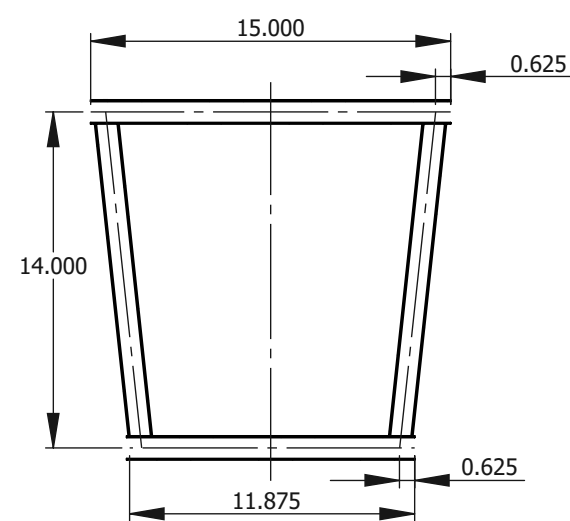
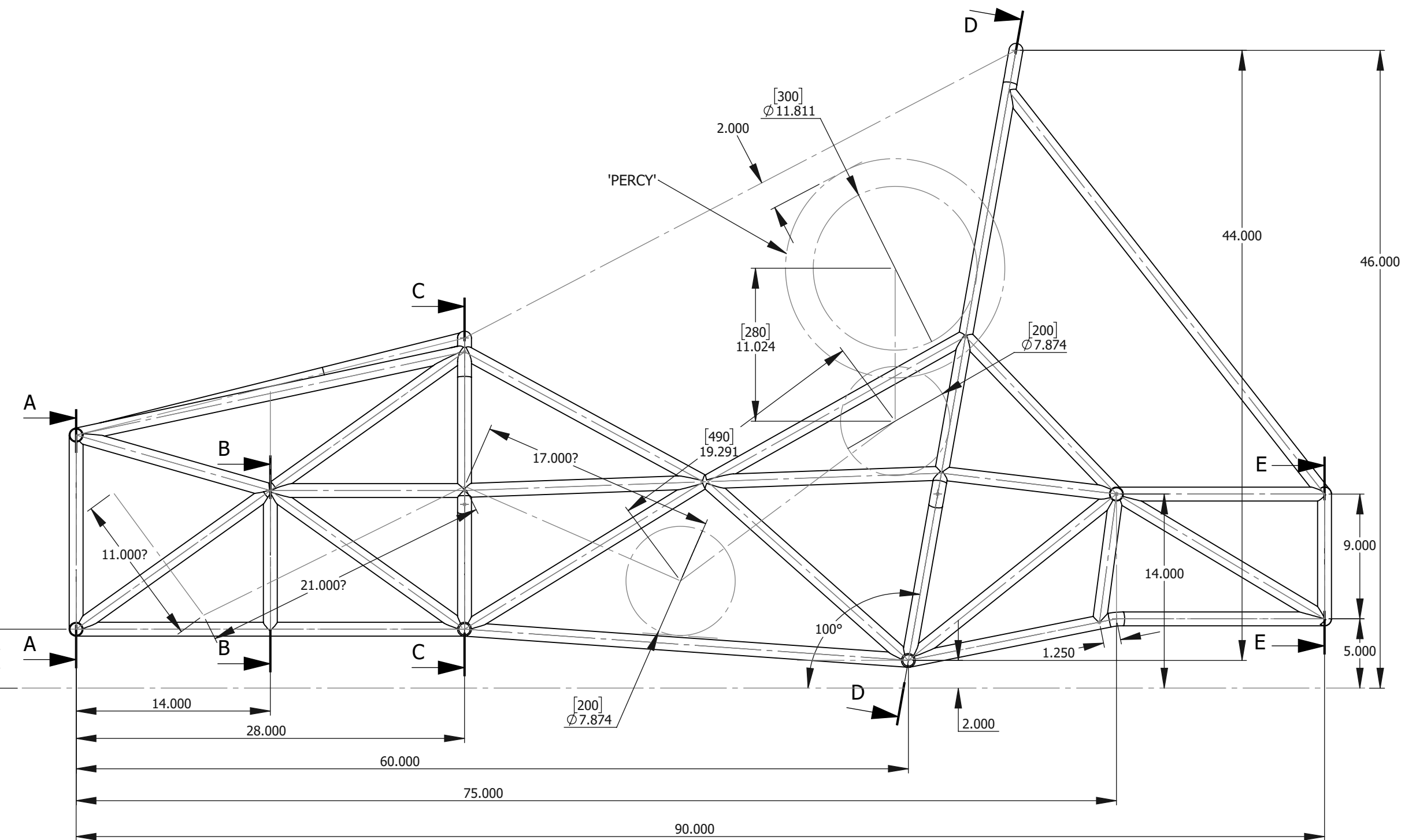
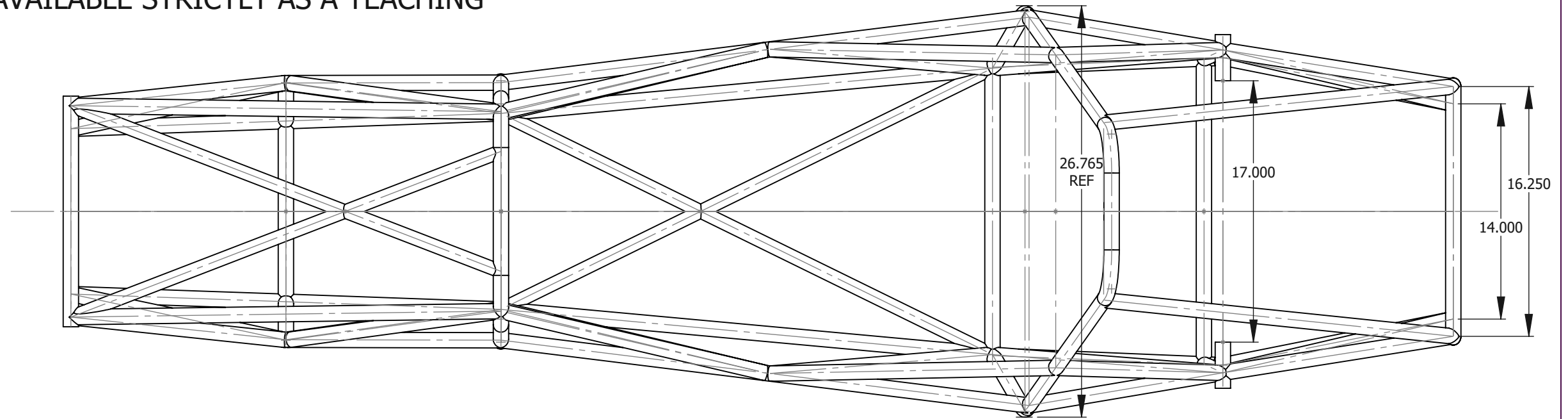
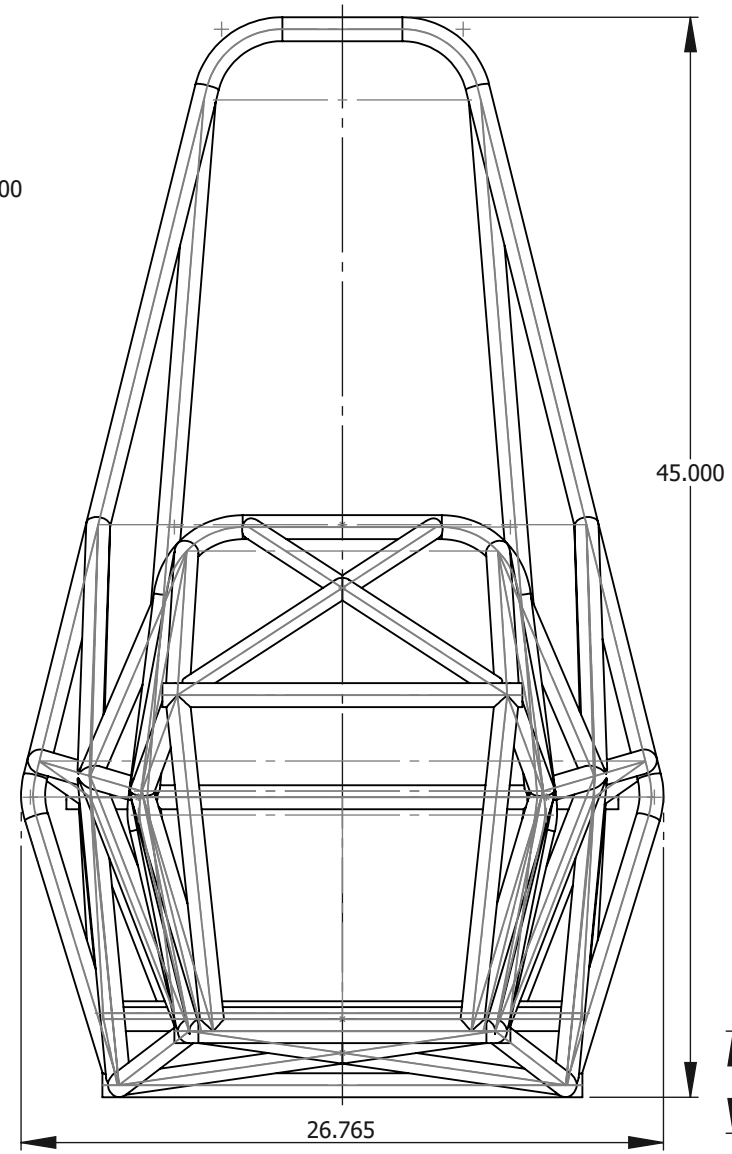

SECTION A-A

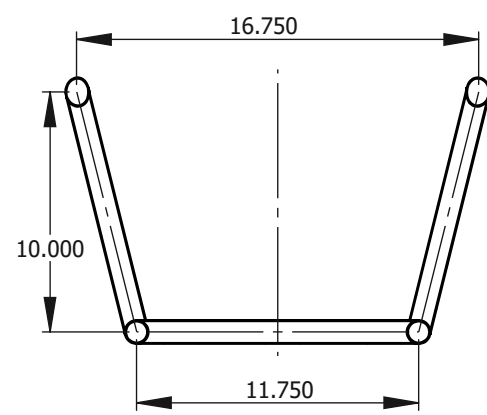

SECTION B-B

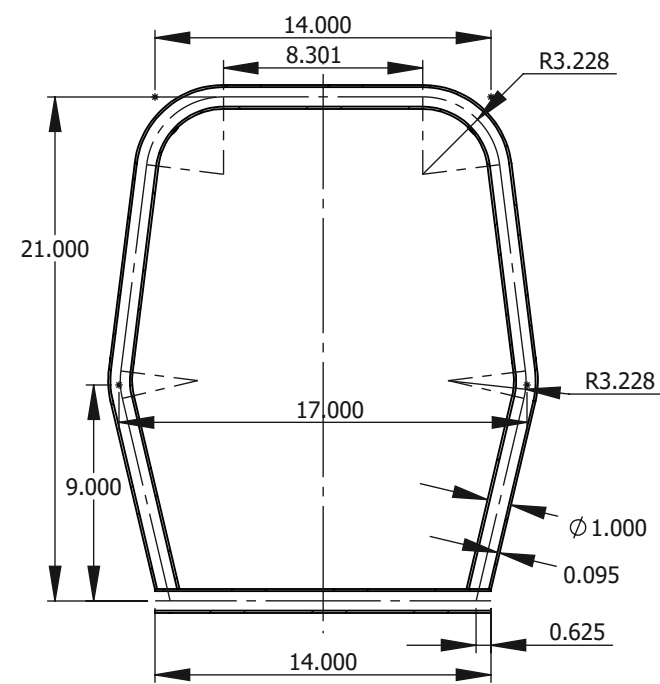

SECTION C-C

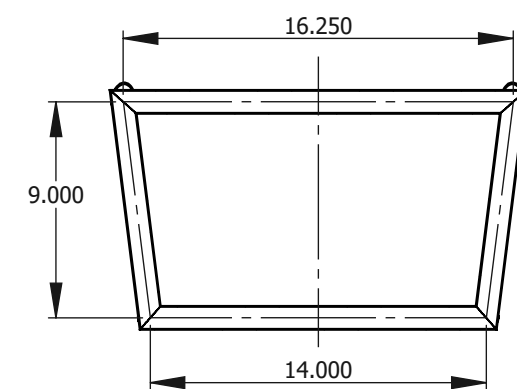

SECTION E-E

REV#	DATE	DRAWN	APPRVD	DESCRIPTION
UNIVERSITY OF ABC				
AWATTO, SOMEWHERE, CANADA				
THIS DRAWING OR THE INFORMATION CONTAINED HEREIN MAY NOT BE REPRODUCED WITHOUT PERMISSION FROM UNIVERSITY OF ABC				
MATERIAL: 4130N STEEL				
LINE2				
LINE3				
DRAWN: P.R.C.	DATE: OCT 22/80	PROJECT NO.	DRAWING NO.	REV NO.
'C' SCALE: 1:5		FSAE '81	10-001-201	0